



Empore™

96-Well Solid Phase Extraction Plates

Instructions for Use

Product Description

Empore™ 96-Well Solid Phase Extraction Plates are designed for high throughput solid phase extraction (SPE). 96 samples can be processed within a standard 8 row by 12 column microtiter plate format. One disk plate can replace four separate runs on a conventional SPE manifold handling 24 individual cartridges per run. The 96 well format is ideal for sample preparation prior to LC/MS/MS or other high throughput analytical techniques.

The plate is molded from a polypropylene resin. An Empore extraction disk is secured in place at the bottom of each well with a sealing ring. A patented prefilter is placed above the Empore disk. This prefilter aids in preventing particulates and macromolecules from reaching the underlying membrane and improves the flow of biological samples, such as serum and plasma, through the plate.

The prefilter is composed of polypropylene microfiber layers of graded densities. Three different densities are used, with the coarsest one on top and the finest at the bottom. The top two microfiber layers are individual layers of material. The third microfiber layer, having the smallest effective pore size, is on the bottom of the prefilter and contains five individual layers of material. A porous polypropylene support membrane comprises the final layer.

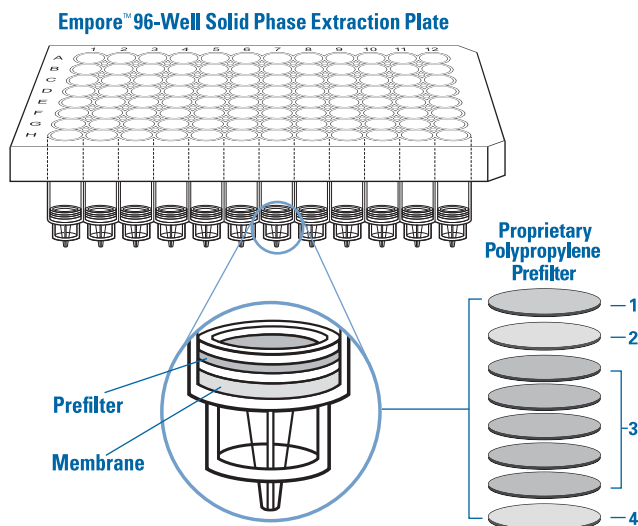

Product Characteristics

Each well of the Empore 96-well solid phase extraction plate has an effective membrane diameter of 5.5 mm. Effective diameter is the diameter of membrane available for use during sample processing. This diameter is smaller than the actual well diameter due to the dimensions of the rings that seal the membrane and prefilter into place. The reservoir volume of the standard plate is 1.2 mL and the volume of the deep well plate is 2.5 mL. If sample or reagent volumes exceed the volume of the well, multiple aliquots of solution may be used.

Standard density (SD) membranes are composed of chromatographic particles commonly referred to as from 30-60 µm in size. The standard density membrane has been optimized for improved flow rates for samples processed in most bioanalytical applications.

Typical Empore™ Extraction Plate Specifications

Membrane diameter	5.5 mm
Well volume	1.2 mL and 2.5 mL
Membrane thickness	0.75 mm
Membrane type	Standard density (SD)
Prefilter composition	Graded density polypropylene
Bed volume	18 µL
Bonded silica sorbent mass (C8, C18 & MPC)	10 mg (nominal)
Universal Resin sorbent mass	5 mg (nominal)
Mean particle size	55 µm (C8 and C18) 44 µm (Universal Resin) 32 µm (Mixed Phase Cation)
Membrane composition	90% or greater sorbent particles 10% or less PTFE

Empore™ Disk Technology

Empore™ Solid Phase Extraction Disks are produced by trapping sorbent particles within an inert matrix of polytetrafluoroethylene (PTFE). The resulting particle-loaded membrane yields a denser, more uniform extraction bed than can be achieved with traditional loosely packed SPE particles. The result is improved mass transfer kinetics with consistent performance in solid phase extraction methods.

The dense particle packing and uniform distribution within Empore disks offer outstanding sample preparation efficiency and reproducibility of results. Since the diffusion distance between particles is minimized, adsorption is more efficient, and extraction can be accomplished using low sorbent mass. The following performance gains can be realized:

- Reduced solvent volumes
- Small elution volumes
- Reduced time for eluate evaporation
- Potential elimination of eluate evaporation
- Higher throughput
- Channeling effects eliminated
- Excellent reproducibility/low CVs

Standard Density

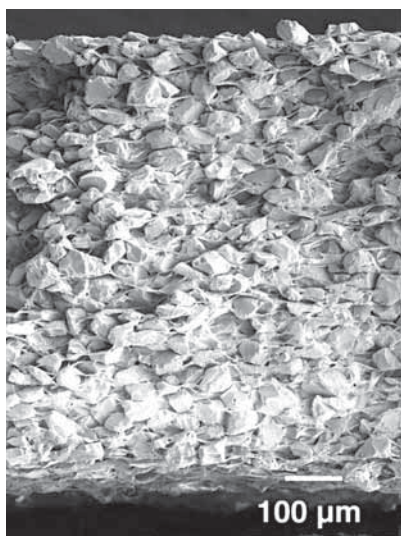

Cross section of a standard density (SD) Empore™ disk (30-60 μm particle size)

Plate Processing Equipment

The dense particle packing of the disk prevents samples from flowing by gravity through the membrane. Vacuum, positive pressure, and centrifugation can all be used to process liquids through the membrane.

Vacuum Manifold

The Empore™ 96-Well Solid Phase Extraction Plate differs in design from plates offered by other manufacturers and requires a specific vacuum manifold that is supplied (Empore™ Vacuum Manifold Cat. 610). Manifolds supplied by different plate manufacturers are specific to the design of their respective plates and cannot generally be used with plates from other manufacturers. In some cases, the use of spacers to raise/lower the height of a collection device inside the manifold may overcome some incompatibility, but must specifically be determined for each combination of manufacturer's manifold and the collection device.

The Empore vacuum manifold (Cat. 610) is illustrated below. A waste tray is shown that is used for liquid collection during the conditioning, loading and washing steps of the extraction process.

During the elution step, several types of collection devices may be used. These include deep well plates, shallow well plates, or racks of collection tubes. Please refer to the "Collection Device Options" section for more information about collection plates.

Plates can be processed manually on a vacuum manifold using multichannel pipettors (8- or 12-channel) for liquid transfers.

The basic items needed include:

- A rack of pipette tips.
- Several disposable reservoir trays to hold each liquid (e.g., conditioning, wash and elution solvents).
- A collection device (plate or microtube format) for the eluate.
- A placeholder, such as an 8-well cover strip, may also be useful.

If samples are not contained in the 8 x 12 microtiter format before use, individual transfers will be necessary from vials or tubes into respective positions within the disk plate.

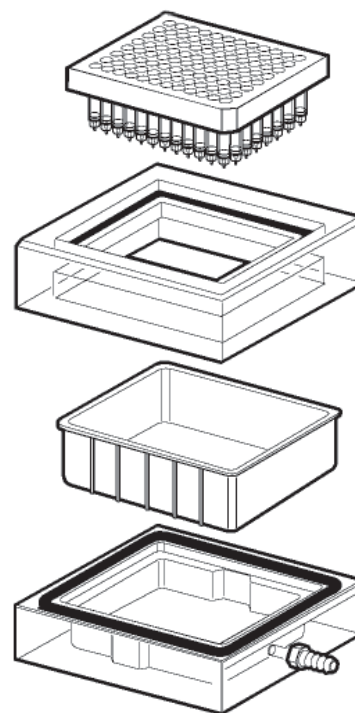

Plate Processing Equipment (continued)

Centrifugation

Centrifugation is a very effective method for processing liquids through the plate. The high forces attainable with centrifugation are advantageous to displace liquids after each step (e.g., to fully remove aqueous wash before the elution step). The Empore™ 96-Well Solid Phase Extraction Plate is nested within a collection device, such as a deep well plate, or rack of microtubes, and this combination is inserted into a microplate carrier that is connected to the rotor. Centrifuges are available that process from two to four microplates per run.

Centrifugation times and speeds should be optimized for individual samples and analytes. Sample loading and eluting should be evaluated at different G forces to check the impact on analyte recovery. Some general guidelines for getting started are found below:

Sample	Sample Extraction	Elution
Buffer	100 G/2 minutes	100 G/2 minutes
Serum diluted 1:3	100 G/2 minutes	100 G/2 minutes
Serum diluted 1:1	250 G/2 minutes	100 G/2 minutes
Undiluted serum	250 G/2 minutes	100 G/2 minutes

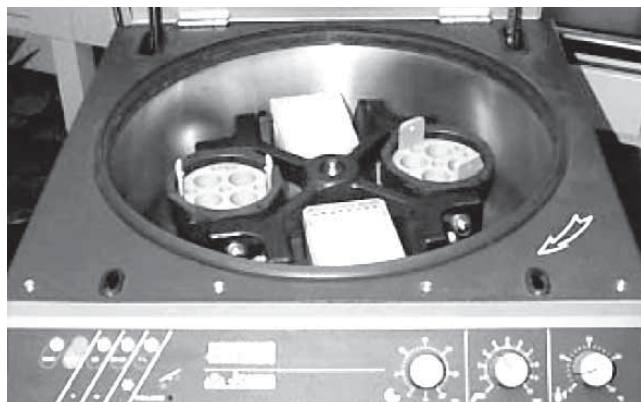

Centrifugation is an effective method to process liquids through the Empore™ extraction disk plate

Liquid Handling Robots

The throughput gains provided by the Empore 96-well solid phase extraction plate attain an even higher level of performance when the extraction is automated, thereby eliminating the possibility for human pipetting error and/or procedural error. Commercially available liquid handling workstations provide a variety of automation solutions since many are designed to work with the microtiter plate format.

Vacuum Recommendations

Empore 96-well solid phase extraction plates generally require from 10-20 inHg (0.34 to 0.68 bar) vacuum to process biological fluids such as plasma and serum through all 96 wells of the plate. If the sample matrix is relatively clean and of a small volume, lower vacuum may be used. However, a general guide is to open the vacuum source to about 17 inHg (0.58 bar) for all steps, with the following exceptions:

1. During method optimization, try loading the sample matrix at both a low vacuum (5-7 inHg; 0.17 to 0.24 bar) and a high vacuum (about 17-20 inHg; 0.58 to 0.68 bar). Compare recoveries at both levels of vacuum and select the vacuum setting that optimizes recoveries. If an analyte has a low affinity for the sorbent, it may need to pass through the sorbent bed more slowly during the loading step for sufficient sorption to occur.
2. Lower vacuum during the elution step will yield a slower flow rate, which is important to prevent splashing in shallow well collection plates.
3. Lower vacuum/slower flow rate may also be beneficial when eluting from MPC sorbent, as more time may be needed to disrupt ionic interactions.

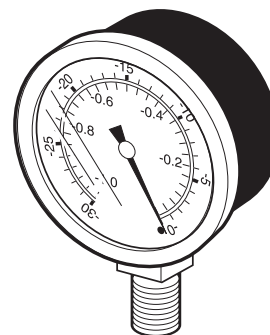

Maintaining Uniform Flow

To maintain uniform flow between wells and avoid loss of vacuum caused by some wells emptying faster than others, several approaches should be considered.

1. During sample loading, inconsistent flow is generally caused by differences in sample viscosities between wells within a 96 well plate. If possible, avoid loading buffer and plasma samples within the same plate. Viscosity differences can also be addressed by diluting serum and plasma samples. Depending on sample size and well volume within the plate, plasma or serum samples may be diluted up to 1:4 with buffer.
2. During the wash and elution steps, it is important to avoid precipitating proteins that can reduce flow through the disk. The most effective method of eliminating proteins is to follow the sample load step immediately with a 100% water wash before washing with solutions containing a small percentage of organic. Please refer to the Empore™ High Performance Extraction Disk Plates Method Optimization Guide for more detailed information.
3. If the above techniques fail to resolve the problem, centrifugation of plates and the use of positive pressure may be considered as alternative processing approaches.

Sealing Unused Wells

Empore Cat. 660 Sealing Tape Pads are suggested to cover unused wells during an extraction assay. Use a clean sheet each time for maximum sealing ability. Do not try to reuse a sheet. *Note that these sheets are not recommended for sealing collection plates before injection.* After a partial plate is used, an additional sheet can be employed to cover the used portion so that it is not mistakenly used again.

Empore 96-Well Solid Phase Extraction Plates are designed as a single use consumable item and are not warranted for multiple uses.

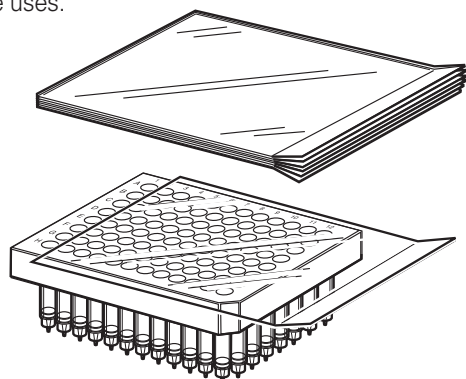

Sealing Unused Wells with Cat. 660 Sealing Tape Pad

Collection Device Options

The illustration below represents some typical collection device options for use with the 96-well extraction disk plate. Cross contamination can be prevented by fitting the collars of the Empore Extraction Disk Plate inside the well of the collection plate. Polypropylene shallow well plates are used for very small elution volumes and are available in either a round U-bottom or a tapered V-bottom configuration. Microtubes are individual polypropylene tubes arranged in a rack conforming to the 8 x 12 microtiter array. Individual assay conditions, elution volumes and subsequent eluate handling procedures define the selection of a collection device.

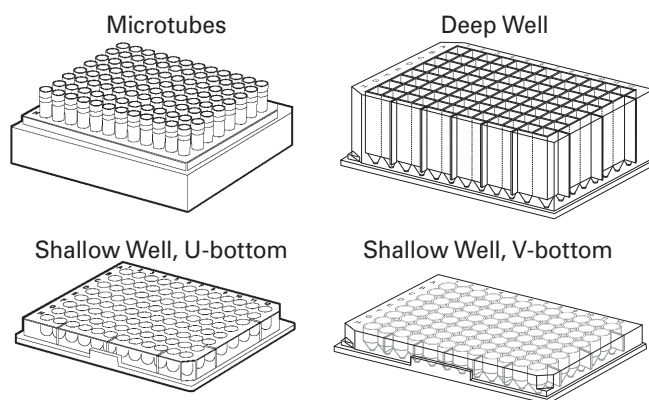

Elution Using Glass Inserts

Other collection device options, such as smaller volume microtubes and smaller volume deep well plates can be used. Microtubes are another option and are available in strips of eight connected tubes as well as individual tubes. If glass is preferred as a collection device instead of polypropylene, deep and shallow well plates can be used with glass inserts, either capped (PTFE septum) or uncapped.

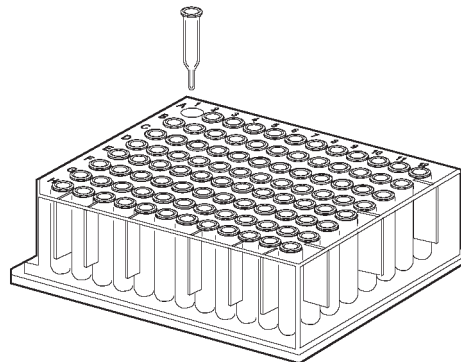

Eluate Handling

The Empore™ Vacuum Manifold Cat. 610 accepts deep and shallow well collection plates and microtubes. Spacers supplied with the manifold may be used to raise the collection device to the optimal distance below the tips of the disk plate. The illustrations below show that two spacers are used with a deep well plate, no spacers are necessary for the microtubes, and a shallow well plate uses an empty microtube rack as a spacer.

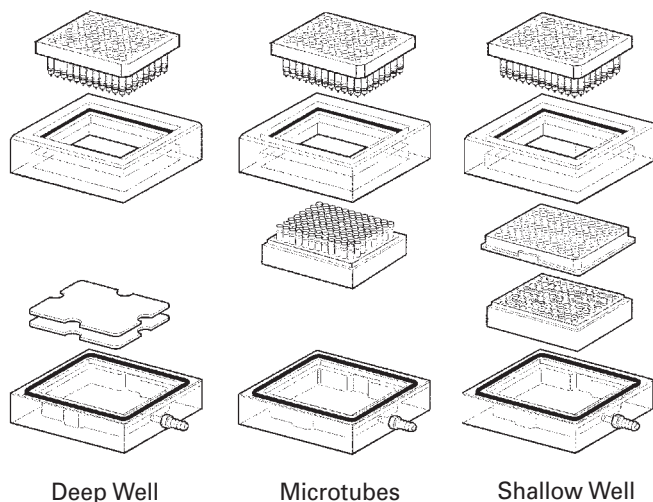

Optimal Heights of Plates with Various Collection Devices

The optimal distances between disk plate tip and collection plate are shown in the accompanying illustrations. Using two spacers, the collar of the disk plate fits into the wells of the deep well plate before the vacuum is applied. After vacuum is turned on, the plate will lower further. These conditions help to avoid cross contamination and ensure eluate integrity.

A shallow well plate does not hold much volume, so it is important to use this plate with caution to avoid overfilling the wells. The tips of the disk plate should fit just into the top of the well. Once vacuum is turned on, the tips will lower themselves a bit more. *The important point to remember is that the tip of the plate must not touch any liquid collected in the well!* Bubble formation can cause liquid splashing out of the well and into an adjacent well. Shallow well plates work best with eluate volumes of 150 μL or less.

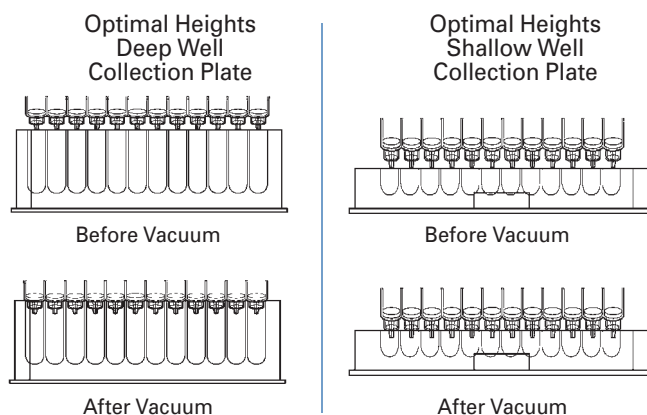

Autoinjectors are commercially available that accept deep and/or shallow well plates. After covering the plate with an appropriate material for sealing, it can be loaded into the injector for analysis, eliminating the need for sample transfer to individual vials. Collection plate manufacturers provide a variety of options to seal plates. The analyst must prioritize the assay needs (evaporation, contamination, freezing, storage, resealable, etc.) and select the appropriate sealing method.

Volume Guidelines

Reversed Phase Extractions

The small bed mass of sorbent in the disk allows for the use of small solvent volumes. A general guide to solvent volumes for a disk SPE method using reversed phase sorbents (C18, C8 or Universal Resin) is listed in this figure. Each assay will need further optimization in terms of selecting the best wash solvent composition (10% methanol, for instance, will not be optimal for all assays) and the elution solvent. It is recommended that the volume of elution solvent always be optimized, as it will vary depending on the analyte, its affinity for the chosen sorbent, and the strength of the eluting solvent.

Example SPE Method for Empore™ C18, C8 or Universal Resin Plates

Condition

100 µL Methanol
200 µL Water or Buffer

Load

96 Samples into Disk Plate

Wash

500 µL Water
200-500 µL Methanol/Water (10/90)

Elute

100-150 µL Organic Solvent
Dilute with Aqueous Component*
(commonly 1-3 times volume of organic used)

Direct Inject Aliquot LC/MS/MS

* Resulting mixture is compatible with mobile phase for direct injection

Mixed Phase Extractions

A general solvent volume guide is listed below for a disk SPE method using mixed phase cation (MPC) exchange sorbent. The MPC sorbent is silica bonded with both octyl (C8) and benzene sulfonic acid groups. The conditioning, load and wash volumes should not vary much. However, it is recommended that the volume of elution solvent be optimized to identify the minimum volume that will elute the drug reproducibly from the phase. Two common elution solvent choices are shown. Alternate solvents which may be used include methanol/ NH_4OH or acetonitrile/ NH_4OH (98/2, v/v).

Example SPE Method Using Empore™ Mixed Phase Cation Plates

Condition

100 µL Methanol
200 µL Water
200 µL Buffer

Load

96 Samples into Disk Plate
(Typically 50:50 Sample:Buffer, v/v)

Wash

500 µL Water
500 µL Acetic Acid 1.0 M
500 µL Methanol

Elute

150-300 µL ACN:IPA: NH_4OH
or CH_2Cl_2 :IPA: NH_4OH (78:20:2, v/v/v)

Evaporate Solvent Reconstitute In Mobile Phase

Inject Aliquot LC/MS/MS

Conditioning Approaches

The thin bed volume of the Empore™ disk allows for the use of small solvent volumes. Given that conditioning can be performed with 4 to 5 times the bed volume, a 100 μL volume of methanol is sufficient to condition the disk. Methanol quickly soaks into the prefilter and disk, and water (200 μL) can be immediately added without a vacuum step between the two additions. Larger volumes of methanol and water can be used, but a vacuum step is necessary after each addition. The disk is reported to be less susceptible to drying out during conditioning than traditional packed particle beds.

An advanced conditioning scheme which further exploits the unique properties of the Empore membrane was published by Pfizer [Janiszewski et al., *Rapid Communications in Mass Spectrometry*, 11, 1033-1037 (1997)]. In the reported assay, a semi-automated liquid handling workstation (Tomtec® Quadra 96™) allowed the dispensing of methanol (50 μL), followed by an air gap (25 μL), then serum (300 μL) in rapid succession from the same pipette tip. A water step was omitted and vacuum was on during this addition. This novel technique can be evaluated for different analytes, sample matrices, and sorbent types for increased sample prep throughput.

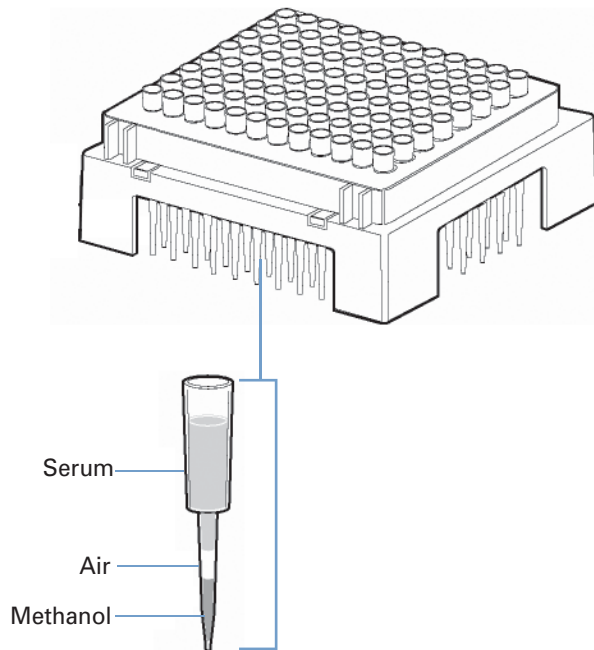

Eliminating the Evaporation Step

The small bed volume of the Empore disk format allows for the use of reduced elution volumes, often eliminating the need for a time-consuming evaporation and reconstitution step. A common approach is to elute with a small volume of organic solvent, then add a volume of aqueous liquid so that the composition of the resulting solution is compatible with mobile phase. Another approach is to elute using a solvent with sufficient organic content to desorb analyte but which is also compatible with mobile phase for direct injection.

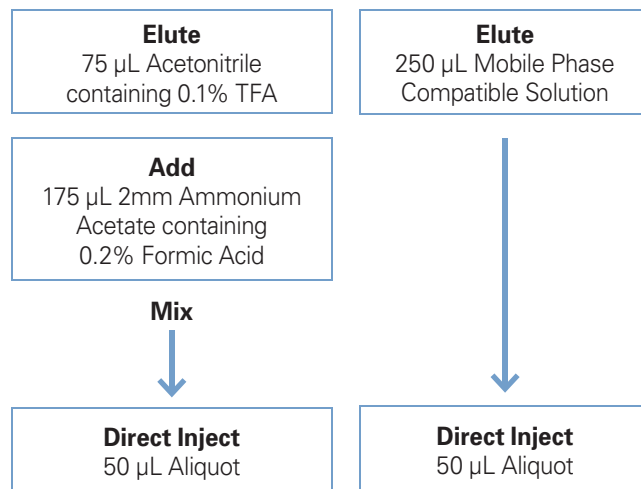

Evaporating Solvent Before Reconstitution

Some assays [e.g., mixed phase cation (MPC)] may require the dry-down of eluate (using nitrogen gas, either with or without a heating block) and reconstitution in another solvent suitable for injection. Options are commercially available from a number of suppliers for 96-well plate dry-down.

For more information on enhancing approaches to conditioning, washing, loading and eluting, please refer to the Empore™ 96-Well Solid Phase Extraction Plate “Method Optimization Guide.”

Identifying 96-Well Solid Phase Extraction Plate Lot Numbers



Refer to the label on the Empore™ 96-Well Solid Phase Extraction Plate (sample shown above) to identify the sorbent chemistry and membrane lot number.

MPC = Mixed Phase Cation.

Note: Empore Sample Preparation Products are intended for solid phase extraction during scientific research only. These products are not intended for use in medical devices or in assessment and treatment of clinical patients.

Important Notice

3M MAKES NO WARRANTIES, EXPRESS OR IMPLIED, INCLUDING, BUT NOT LIMITED TO, ANY IMPLIED WARRANTY OF MERCHANTABILITY OR FITNESS FOR A PARTICULAR PURPOSE. Since a variety of factors can affect the use and performance of a 3M product in a particular application, some of which are uniquely within the user's knowledge and control, user is responsible for determining whether or not the 3M product is fit for a particular purpose and suitable for user's method of application.

Warranty

Seller warrants its equipment against defects in workmanship and material for a period of 12 months from date of shipment from the factory under normal use and service and otherwise when such equipment is used in accordance with instructions furnished by Seller and for purposes disclosed in writing at the time of purchase, if any. Any unauthorized alteration or modification of the equipment by Buyer will void this warranty. Seller's liability under this warranty shall be limited to the replacement or repair, F.O.B., point of manufacture, of any defective equipment or part which, having been returned to the factory, transportation charges prepaid, has been inspected and determined by Seller to be defective. THIS WARRANTY IS IN LIEU OF ANY OTHER WARRANTY, EITHER EXPRESSED OR IMPLIED, AS TO DESCRIPTION, QUALITY, MERCHANTABILITY, FITNESS FOR ANY PARTICULAR PURPOSE OR USE, OR ANY OTHER MATTER. Under no circumstances shall Seller be liable to Buyer or any third party for any loss of profits or other direct or indirect costs, expenses, losses or consequential damages arising out of or as a result of any defects in or failure of its products or any part or parts thereof or arising out of or as a result of parts or components incorporated in Seller's equipment but not supplied by the Seller.

Technical Information and Data

Technical information and data, recommendations, and other statements provided by 3M are based on information, tests, or experience which 3M believes to be reliable, but the accuracy or completeness of such information is not guaranteed. Such technical information and data are intended for persons with knowledge and technical skills sufficient to assess and apply their own informed judgment to the information. No license under any 3M or third party intellectual property rights is granted or implied with this information.

Safety and Disposal

Always follow safe handling practices while processing Empore products as applicable to your use. Always wear appropriate personal protective equipment while processing Empore products as applicable to your use. Dispose of used Empore products per requirements of your process. Alteration or addition of other materials to Empore products may require unique disposal protocols. Always dispose of used product in accordance with federal, state and local requirements.

3130 Lexington Ave. S.
Eagan, MN 55121
Toll Free: +1 888 509 5330

3M is a trademark of 3M Company.
Empore is a trademark of 3M Company used under license.

Tomtec is a registered trademark of
Tomtec Inc. Corporation. Quadra 96 is a
trademark of Tomtec Inc. Corporation.

© 3M 2009. All Rights Reserved.
Printed in the USA. Issued: 1/09
6326HB 98-0504-1669-6
LITEMP030 0309

